

MTW 400d /F++/3,5m/45°

4,035,951,000

MTW 400d /F++/3.5m/45° (4,035,951,000)

MTW / MHP W ML

TAB. B	
44,0350,3436 - 3,15m (10.33ft)	MTW 250d & MTW 400d
44,0350,3437 - 4,15m (13.61ft)	
44,0350,3438 - 3,15m (10.33ft)	MTW 500d / MHP 500d
44,0350,3439 - 4,15m (13.61ft)	
44,0350,3563 - 3,15m (10.33ft)	MTW 700d / MHP 700d
44,0350,3564 - 4,15m (13.61ft)	

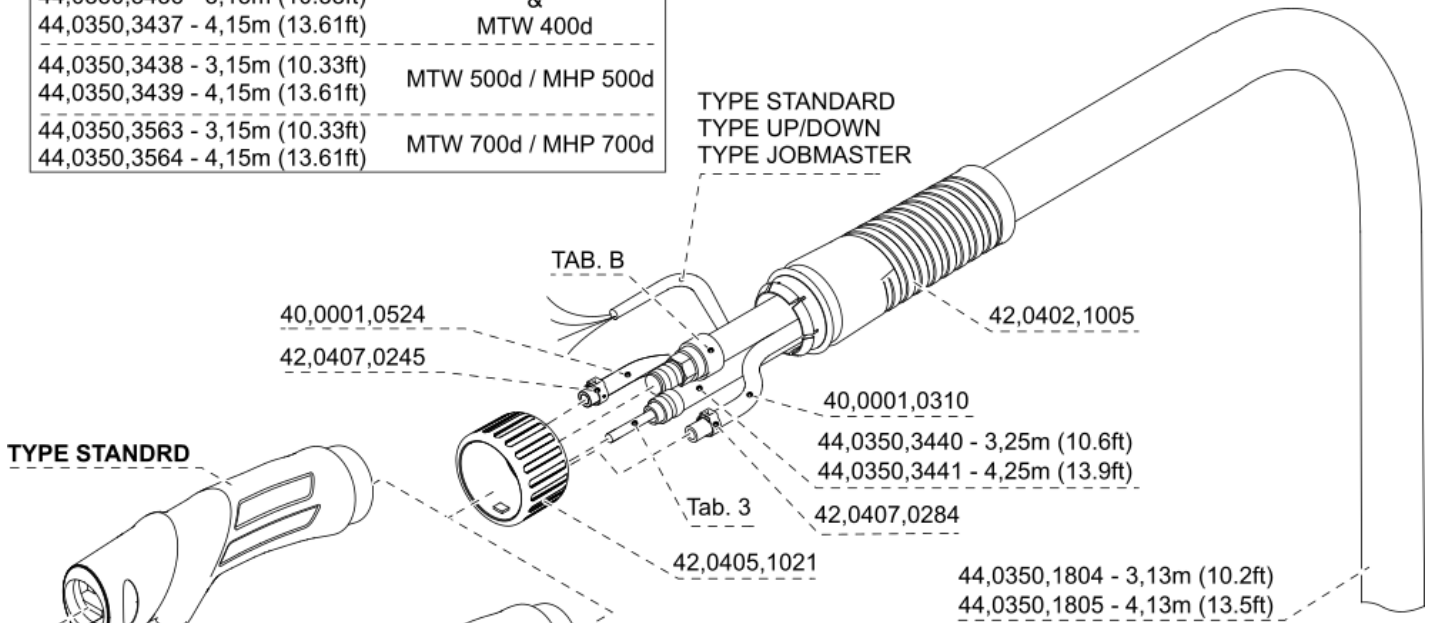

TYPE STANDRD

TYPE UP/DOWN
TYPE JOBMASTER

TORCH BODY
MTB W

42,0407,0438

42,0402,0286

44,0350,3269 - ML

TORCH BODY
MTB W ML

TYPE STANDARD

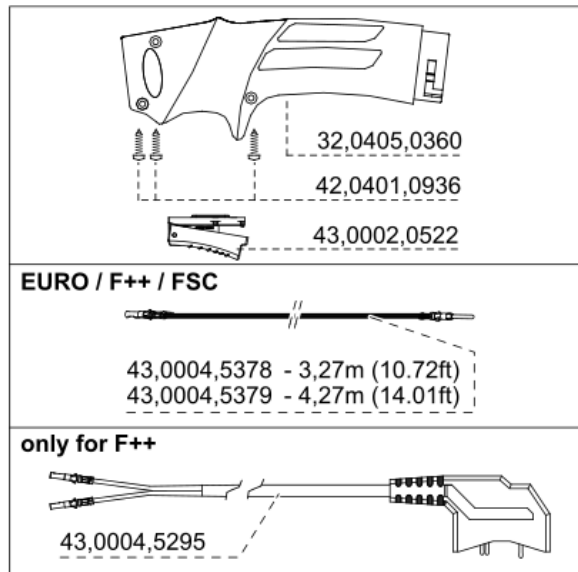

TYPE UP/DOWN

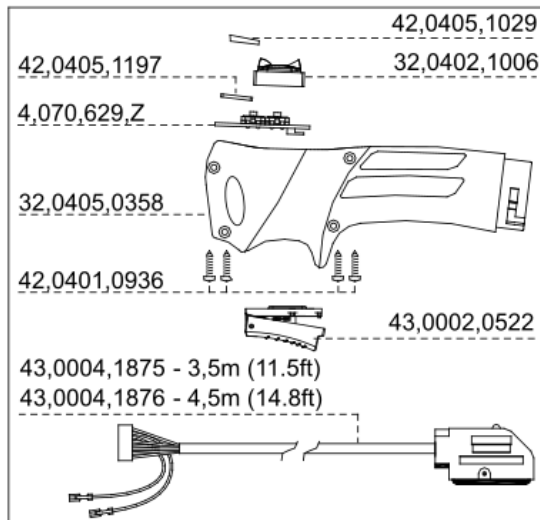

TYPE JOBMASTER

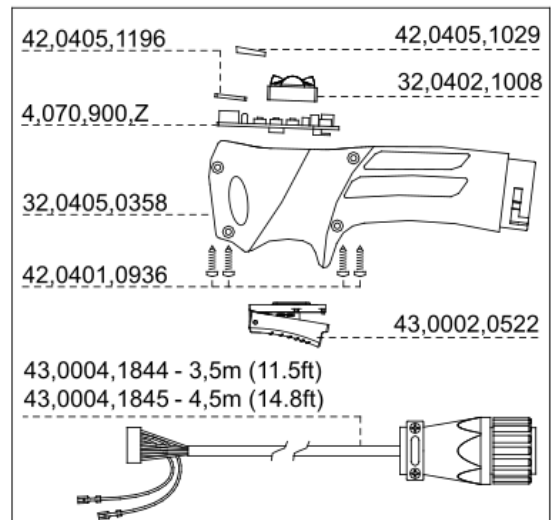

MTW 400d /F++/3.5m/45° (4,035,951,000)

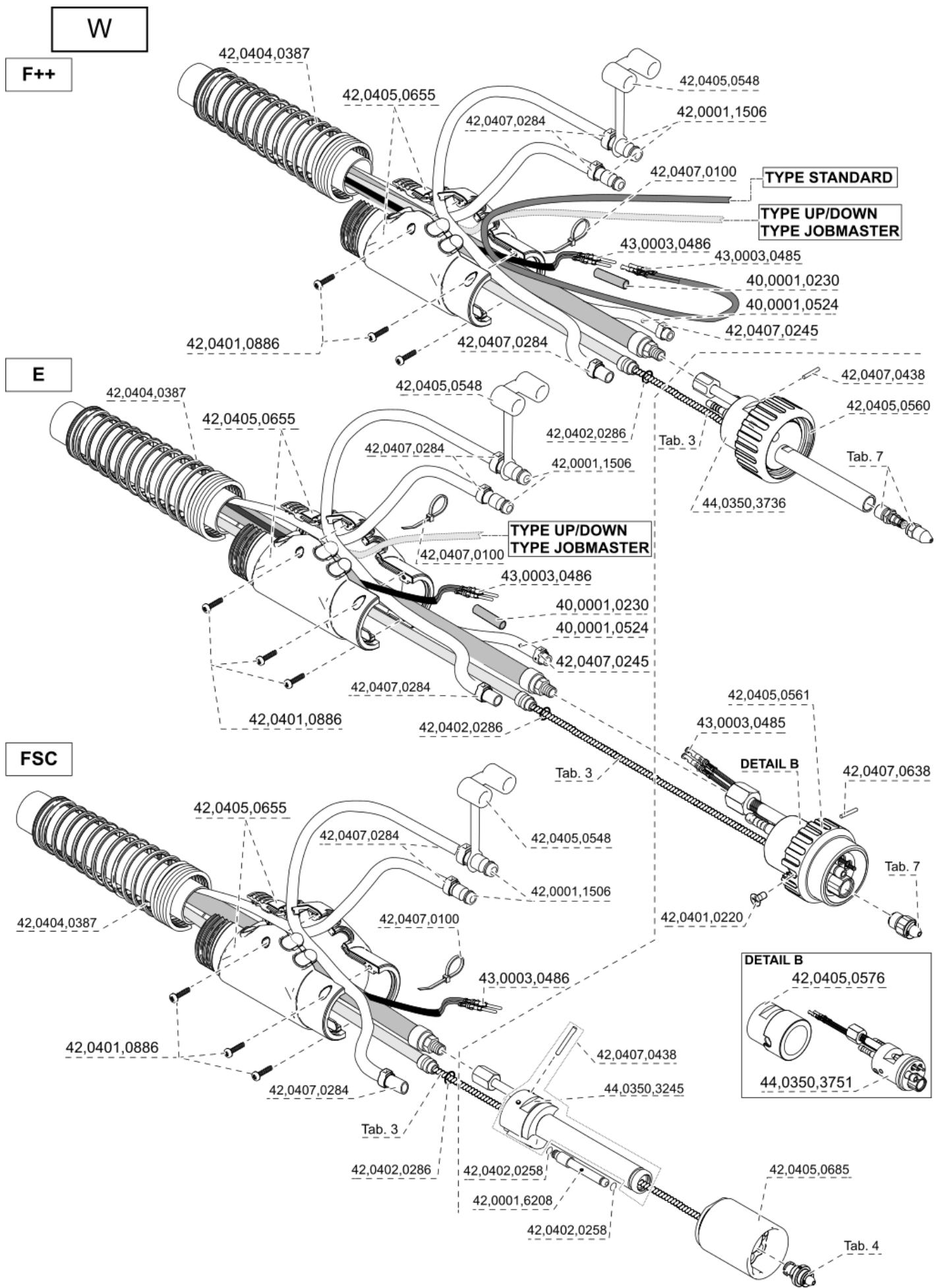

MTW 400d /F++/3.5m/45° (4,035,951,000)

MTW 400i

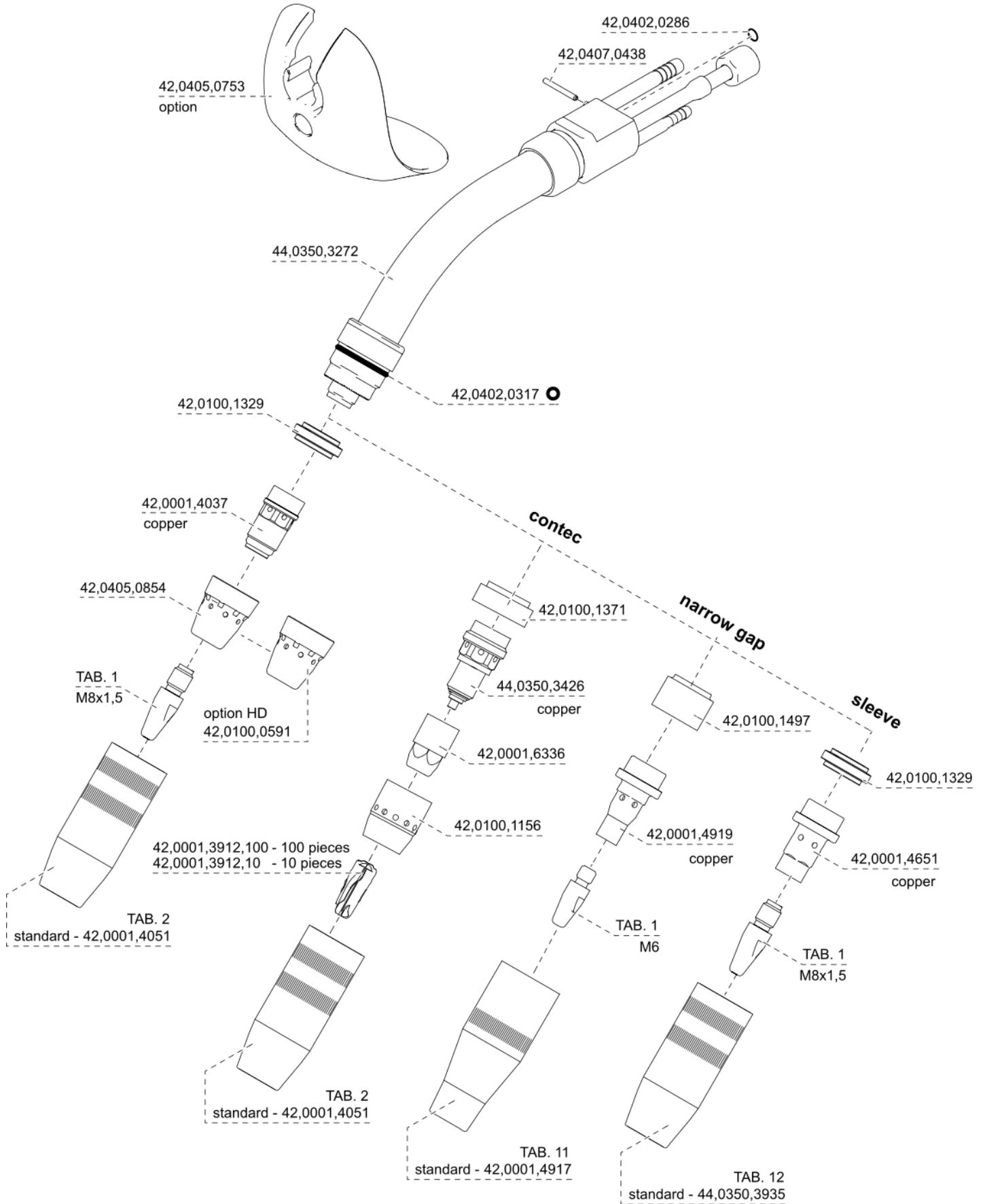

MTW 400d /F++/3.5m/45° (4,035,951,000)

TAB. 1 CuCrZr		Ø mm	Ø inch	Part No.
		0,6	0,023	42,0001,4928
		0,7	0,027	42,0001,6524,10
		0,8	0,030	42,0001,4461,10
		0,9	0,035	42,0001,4462,10
		1,0	0,040	42,0001,4463,10
		1,1	0,043	42,0001,6527,10
		1,2	0,045	42,0001,4464,10
		1,3	0,051	42,0001,6529,10
		1,4	0,052	42,0001,4465,10
		1,5	0,059	42,0001,6522,10
		1,6	0,062	42,0001,4466,10
		0,7	0,027	42,0001,6482,10
		0,8	0,030	42,0001,6464,10
		0,9	0,035	42,0001,6465,10
		1,0	0,040	42,0001,6466,10
		1,1	0,043	42,0001,6483,10
		1,2	0,045	42,0001,6467,10
		1,3	0,051	42,0001,6484,10
		1,4	0,052	42,0001,6468,10
		1,5	0,059	42,0001,6485,10
		1,6	0,062	42,0001,6469,10
		1,8	0,071	42,0001,6470,10
	2,0	0,078	42,0001,6471,10	
	2,4	0,095	42,0001,6472,10	
	2,8	0,110	42,0001,4642,10	
Al 		0,8	0,030	42,0001,6525,10
		1,0	0,040	42,0001,6526,10
		1,2	0,045	42,0001,6528,10
		1,6	0,062	42,0001,6523,10
Al 		0,8	0,030	42,0001,6537,10
		1,0	0,040	42,0001,4750,10
		1,2	0,045	42,0001,4751,10
		1,6	0,062	42,0001,4752,10

TAB. 1 E-Cu		Ø mm	Ø inch	Part No.
		0,9	0,035	42,0001,7025,10
		1,0	0,040	42,0001,7026,10
		1,2	0,045	42,0001,7027,10
		0,9	0,035	42,0001,7028,10
		1,0	0,040	42,0001,7029,10
		1,2	0,045	42,0001,7030,10

MTW 400d /F++/3.5m/45° (4,035,951,000)

TAB. 2

		d1		d2		d3		L		Part No.		
		mm	inch	mm	inch	mm	inch	mm	inch			
MTW 250i	MTG 250i	M20x2										
		8	0.31	22	0.86	10,4	0.41	58	2.28	42,0001,6664		standard MTW 250i Braze
		10	0.39	22	0.86	13,0	0.51	54	2.13	42,0001,4083		
		13	0.51	22	0.86	16,1	0.63	54	2.13	42,0001,4799		
		13	0.51	22	0.86	16,1	0.63	56	2.20	42,0001,4477		standard MTB 250i G/W R
		10	0.39	22	0.86	13,0	0.51	58	2.28	42,0001,4084		
		13	0.51	22	0.86	16,1	0.63	56	2.20	42,0001,4498	AI	
		13	0.51	22	0.86	16,1	0.63	58	2.28	42,0001,4065		standard MTG/MTW 250i
		15	0.59	22	0.86	18,3	0.72	58	2.28	42,0001,4493		
		18	0.71	22	0.86	22	0.87	58	2.28	42,0001,4055		
MTW 400i/500i	MTG 320i/400i	M23x2										
		13	0.51	25	0.98	16,4	0.64	59	2.32	42,0001,4085		
		15	0.59	25	0.98	18,6	0.73	59	2.32	42,0001,4048		
		13	0.51	25	0.98	16,4	0.64	61	2.40	42,0001,4086		standard MTB 320i G R
		15	0.59	25	0.98	18,1	0.71	61	2.40	42,0001,4474		standard MTB 400i W R
		15	0.59	27	1.06	20,2	0.80	61	2.40	42,0001,4789		MTB 400i W R, heavy duty
		17	0.71	25	0.98	20,8	0.82	61	2.40	42,0001,4476		standard MTB 500i W R
		13	0.51	25	0.98	16,4	0.64	61	2.40	42,0001,4497	AI	
		13	0.51	25	0.98	16,4	0.64	63	2.48	42,0001,4080		standard MTG 320i
		15	0.59	25	0.98	18,6	0.73	61	2.40	42,0001,4496	AI	
		15	0.59	25	0.98	18,6	0.73	63	2.48	42,0001,4051		standard MTW 400i
		17	0.71	25	0.98	20,8	0.82	61	2.40	42,0001,4494	AI	
		17	0.71	25	0.98	20,8	0.82	63	2.48	42,0001,4050		standard MTW500i,330i W R long
		17	0.71	27	1.06	20,8	0.82	63	2.48	42,0001,4216		MTW 500i, heavy duty
		21	0.82	25	0.98	25,0	0.98	63	2.48	42,0001,4054		
		15	0.59	25	0.98	18,6	0.73	68	2.68	42,0001,4052		
		17	0.71	25	0.98	20,8	0.82	68	2.68	42,0001,4049		
		13	0.51	25	0.98	16,4	0.64	71	2.80	42,0001,4087		
		15	0.59	25	0.98	18,6	0.73	71	2.80	42,0001,4788		
		13	0.51	25	0.98	16,4	0.64	73	2.87	42,0001,4088		
15	0.59	25	0.98	18,6	0.73	73	2.87	42,0001,4475		standard MTB 400i G R		
15	0.59	27	1.06	18,6	0.73	73	2.87	42,0001,4790		MTB 400i G R, heavy duty		
15	0.59	25	0.98	18,6	0.73	73	2.87	42,0001,4495	AI			
15	0.59	25	0.98	18,6	0.73	75	2.95	42,0001,4045		standard MTG 400i		
17	0.71	25	0.98	20,8	0.82	75	2.95	42,0001,4043				
21	0.82	25	0.98	25,0	0.98	75	2.95	42,0001,4053				
15	0.59	25	0.98	18,6	0.73	80	3.15	42,0001,4047				

TAB. 12

		d1		d2		d3		L		Part No.		
		mm	inch	mm	inch	mm	inch	mm	inch			
MTB W400i W R H	MTB W500i W R H	M23x2										
		15	0.59	ø25	0.98	18,6	0.73	61	2.40	44,0350,3935		standard MTB 400i W R H
		15	0.59	ø25	0.98	18,6	0.73	63	2.48	44,0350,1287		
		17	0.66	ø25	0.98	20,8	0.82	61	2.40	44,0350,3936		standard MTB 500i W R H

TAB. 5

MTB 700i
MTW 750i

42,0402,0304
Ø 25x1,5mm

42,0402,0305
Ø 21x1,5mm

42,0402,0305
Ø 21x1,5mm

	d1		d2		d3		L		Part No.		
	mm	inch	mm	inch	mm	inch	mm	inch			
①	17	0.66	ø29	1.10	22	0.86	71	2,79	44,0350,3966		Standard MTW 700i/750i
②	17	0.66	ø29	1.10	22	0.86	29	1.14	42,0001,4257		Standard MTW 700i/750i
①	17	0.66	ø29	1.10	22	0.86	76	3.00	44,0350,3942		HD
②	17	0.66	ø29	1.10	22	0.86	34	1.34	42,0001,4670		HD
①	17	0.66	ø29	1.10	22	0.86	68,5	2.70	44,0350,4079		Standard MTB 700i W R
②	17	0.66	ø29	1.10	22	0.86	26,5	1.04	42,0001,4868		Standard MTB 700i W R
①	17	0.66	ø29	1.10	22	0.86	69	2.72	44,0350,0226		Laser Hybrid
②	17	0.66	ø29	1.10	22	0.86	27	1.06	42,0001,0142		Laser Hybrid

MTW 400d /F++/3.5m/45° (4,035,951,000)

TAB. 6														
		d1		d2		d3		L		Part No.				
		mm	inch	mm	inch	mm	inch	mm	inch					
MTB G 330i R	MTB W 330i R	M23x2		13	0.51	ø25	0.98	16	0.63	37	1.46	42,0001,4533		not possible at MTB 330i G R H standard MTB 330i W R / G ML
		13	0.51	ø25	0.98	16	0.63	41	1.61	42,0001,4487				
		13	0.51	ø25	0.98	16	0.63	39,5	1.61	42,0001,4534	Al		standard MTB 330i G R G R H	
		13	0.51	ø25	0.98	16	0.63	39,5	1.56	42,0001,4902				
		15	0.59	ø25	0.98	18	0.72	39,5	1.56	42,0001,5023				

TAB. 7												
		d1		d2		d3		L		Part No.		
		mm	inch	mm	inch	mm	inch	mm	inch			
MTB W 330i W R H	M23x2	13	0.51	ø25	0.98	16	0.63	41	1,61	42,0001,4486		standard MTB 330i W R H

TAB. 8												
		d1		d2		d3		L		Part No.		
		mm	inch	mm	inch	mm	inch	mm	inch			
MTB W 330i R MTB G 330i R	M23x2	13	0.51	ø25	0.98	16	0.63	56	2.21	42,0001,4745		
		13	0.51	ø25	0.98	16	0.63	50	1.97	42,0001,6772		

TAB. 9												
		d1		d2		d3		L		Part No.		
		mm	inch	mm	inch	mm	inch	mm	inch			
MTB G 330i R long	M23x2	13	0.51	ø27	1.06	18	0.72	53	2.09	42,0001,4858		standard MTB 330i G R
		15	0.59	ø27	1.06	18	0.72	53	2.09	42,0001,4857		
		15	0.59	ø27	1.06	18	0.72	57	2.09	42,0001,4856		

TAB. 10												
		d1		d2		d3		L		Part No.		
		mm	inch	mm	inch	mm	inch	mm	inch			
MTG 550i	M25x3	15	0.59	ø27	1.06	19	0.75	67	2.64	44,0350,2020		standard MTG 550i
		17	0.67	ø27	1.06	21	0.83	67	2.64	44,0350,2021		
		15	0.59	ø27	1.06	19	0.75	74	2.91	44,0350,1991		
		17	0.67	ø27	1.06	21	0.83	74	3.91	44,0350,1995		
		15	0.59	ø27	1.06	19	0.75	80,5	3.17	44,0350,1987		
		15	0.59	ø27	1.06	19	0.75	82,5	3.25	44,0350,1988		
		17	0.67	ø27	1.06	21	0.83	83,5	3.29	44,0350,3179		
		18	0.71	ø27	1.06	22	0.89	87,5	3.44	44,0350,3180		

TAB. 11												
		d1		d2		d3		L		Part No.		
		mm	inch	mm	inch	mm	inch	mm	inch			
MTB 400/500i W R MTB 320/400i G R	M23x2	13	0.51	ø25	0.98	16	0.63	62,5	2.46	42,0001,4917		standard MTB 320i G / 400/500i W
		10	0.39	ø25	0.98	16	0.63	68,0	2.68	42,0001,6715		
		13	0.51	ø25	0.98	16	0.63	68,0	2.68	42,0001,6716		standard MTB 400i G
		13	0.51	ø25	0.98	16	0.63	74,5	2.93	42,0001,4918		

TAB. 14												
		d1		d2		d3		L		Part No.		
		mm	inch	mm	inch	mm	inch	mm	inch			
MTG 400i	plug	15	0.51	ø25	0.79	19	0.63	69,5	2.91	42,0001,0972		standard MTB 400i G

TAB. 15												
		d1		d2		d3		L		Part No.		
		mm	inch	mm	inch	mm	inch	mm	inch			
MTW 500i	plug	17	0.66	ø27	1.06	22,2	0.87	85	3.34	44,0350,2036		standard MTB 500i W

MTW 400d /F++/3.5m/45° (4,035,951,000)

Tab. 3.1

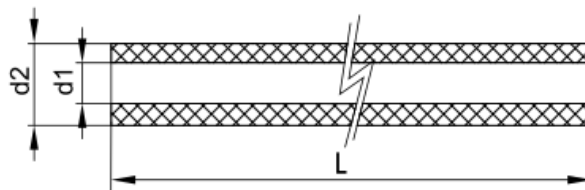

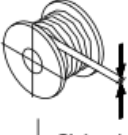
material			d1		d2		Part No. L		Part No. L		Part No. L	
	Ø mm	Ø inch	mm	inch	mm	inch	10m 32.8feet	30m 98feet	100m 328feet			
Graphit	0,8	.030	1,2	.047	4,7	.185	40,0001,0529,010	40,0001,0529,030	40,0001,0529,100			
Graphit	0,9-1,0	.035-.040	1,5	.059	4,7	.185	40,0001,0530,010	40,0001,0530,030	40,0001,0530,100			
Graphit	1,2	.045	1,8	.070	4,7	.185	40,0001,0531,010	40,0001,0531,030	40,0001,0531,100			
Graphit	1,4-1,6	.052-1/16	2,4	.094	4,7	.185	40,0001,0532,010	40,0001,0532,030	40,0001,0532,100			
Graphit	0,8	5/64	3,0	.118	4,7	.185	40,0001,0533,010	40,0001,0533,030	40,0001,0533,100			

MTW 400d /F++/3.5m/45° (4,035,951,000)

Tab. 3

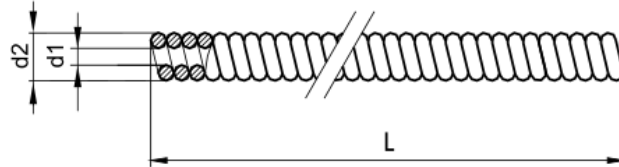

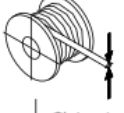
material			d1		d2		Part No. L		Part No. L	Part No. L		
	Ø mm	Ø inch	mm	inch	mm	inch	5m	16.4feet	15m	49.2feet	50m	160feet
Steel liner	0,8	.030	1,4	.055	4,4	.176	40,0002,0040,005		40,0002,0040,015		40,0002,0040,050	
Steel liner	0,9 - 1,0	.035/.040	1,6	.062	4,8	.189	40,0002,0041,005		40,0002,0041,015		40,0002,0041,050	
Steel liner	1,2	.045	1,9	.074	4,9	.192	40,0002,0042,005		40,0002,0042,015		40,0002,0042,050	
Steel liner	1,4 - 1,6	.052/.062	2,5	.098	4,9	.192	40,0002,0043,005		40,0002,0043,015		40,0002,0043,050	
CrNi liner	0,8	.030	1,4	.055	4,4	.176	40,0002,0044,005		40,0002,0044,015		40,0002,0044,050	
CrNi liner	0,9 - 1,0	.035/.040	1,6	.062	4,8	.189	40,0002,0045,005		40,0002,0045,015		40,0002,0045,050	
CrNi liner	1,2	.045	1,9	.074	4,9	.192	40,0002,0046,005		40,0002,0046,015		40,0002,0046,050	
CrNi liner	1,4 - 1,6	.052/.062	2,5	.098	4,9	.192	40,0002,0047,005		40,0002,0047,015		40,0002,0047,050	
Steel liner coated	0,8	.030	1,4	.055	4,4	.176	40,0002,0052,005		40,0002,0052,015		40,0002,0052,050	
Steel liner coated	0,9 - 1,0	.035/.040	1,6	.062	4,8	.189	40,0002,0053,005		40,0002,0053,015		40,0002,0053,050	
Steel liner coated	1,2	.045	1,9	.074	4,9	.192	40,0002,0054,005		40,0002,0054,015		40,0002,0054,050	
Steel liner coated	1,4 - 1,6	.052/.062	2,5	.098	4,9	.192	40,0002,0055,005		40,0002,0055,015		40,0002,0055,050	

Tab. 3

combi liner W AL

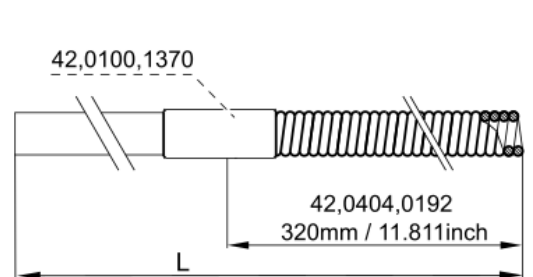
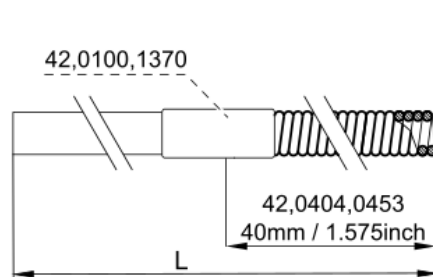
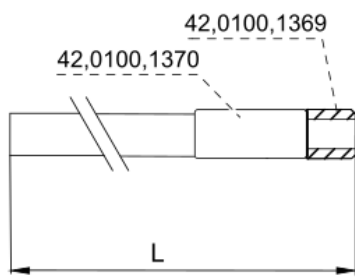

combi liner G AL

combi inner liner G

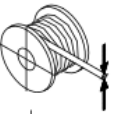

		L		d1		d2		combi liner W AL	combi liner G AL	combi inner liner G
Ø mm	Ø inch	m	feet	mm	inch	mm	inch	Part No.	Part No.	Part No.
0,8	.030	2,0	6.5	1,2	.059	4,7	.185	44,0350,3388	44,0350,3400	44,0350,5550
0,8	.030	3,8	12.4	1,2	.059	4,7	.185	44,0350,3392	44,0350,3404	44,0350,5513
0,8	.030	4,8	15.7	1,2	.059	4,7	.185	44,0350,3396	44,0350,3408	44,0350,5518
0,9 - 1,0	.035/.040	2,0	6.5	1,5	.062	4,7	.185	44,0350,3389	44,0350,3401	44,0350,5551
0,9 - 1,0	.035/.040	3,8	12.4	1,5	.062	4,7	.185	44,0350,3393	44,0350,3405	44,0350,5514
0,9 - 1,0	.035/.040	4,8	15.7	1,5	.062	4,7	.185	44,0350,3397	44,0350,3409	44,0350,5519
1,2	.045	2,0	6.5	1,8	0.74	4,7	.185	44,0350,3390	44,0350,3402	44,0350,5552
1,2	.045	3,8	12.4	1,8	0.74	4,7	.185	44,0350,3394	44,0350,3406	44,0350,5515
1,2	.045	4,8	15.7	1,8	0.74	4,7	.185	44,0350,3398	44,0350,3410	44,0350,5520
1,4 - 1,6	.052/.062	2,0	6.5	2,4	.098	4,7	.185	44,0350,3391	44,0350,3403	44,0350,5553
1,4 - 1,6	.052/.062	3,8	12.4	2,4	.098	4,7	.185	44,0350,3395	44,0350,3407	44,0350,5516
1,4 - 1,6	.052/.062	4,8	15.7	2,4	.098	4,7	.185	44,0350,3399	44,0350,3411	44,0350,5521
2,0	.045	2,0	6.5	1,2	.059	4,7	.185	44,0350,3615	44,0350,3618	44,0350,5554
2,0	.045	3,8	12.4	3,0	.118	4,7	.185	44,0350,3616	44,0350,3619	44,0350,5517
2,0	.045	4,8	15.7	3,0	.118	4,7	.185	44,0350,3617	44,0350,3620	44,0350,5522

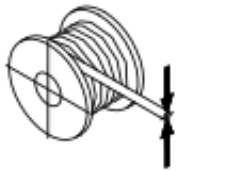
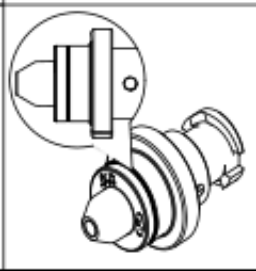
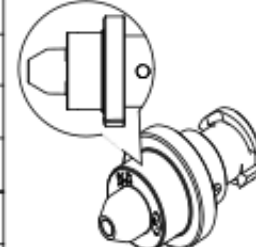
MTW 400d /F++/3.5m/45° (4,035,951,000)

Tab. 4					
MTG / MTW					
 Ø mm Ø inch		Fe / CrNi	Alu / CuSi	colour	
0,8	.031		44,0350,3314	grey	
0,8	.031	44,0350,3315		grey	
0,9-1,0	.039	44,0350,3317		blue	
1,2	.047	44,0350,3318		red	
1,4-1,6	.062	44,0350,3320		black	
2,0	.078		44,0350,3321	green	
2,4	.095		44,0350,4245	brown	
2,0	.078	42,0001,4589			
2,4	.095				
2,8	.110				

MTW 400d /F++/3.5m/45° (4,035,951,000)

Tab. 7

Fe / CrNi

	Fe		Part No.	F/F++	Fe		Part No.
	Ø mm	Ø inch			Ø mm	Ø inch	
	0,8	.030	42,0001,5833		0,8	.030	44,0350,3769
	1,0	.040	42,0001,4512		1,0	.040	44,0350,3770
	1,2	.045	42,0001,4512		1,2	.045	44,0350,3771
	1,6	1/16	42,0001,3583		1,6	1/16	44,0350,3772

Euro	Fe		Part No.	colour
	Ø mm	Ø inch		
	0,8	.030	44,0350,3703	grey
	1,0	.040	44,0350,3704	blue
	1,2	.045	44,0350,3705	red
	1,6	1/16	44,0350,3706	black

Al

	Al		Part No.			Al		Part No.
	Ø mm	Ø inch				Ø mm	Ø inch	
	0,8	.030	42,0001,3583		42,0400,1024	0,8	.030	42,0100,1120 -white
	1,0	.040	42,0001,3583			0,9	.035	42,0100,1119 -blue
	1,2	.045	42,0001,3583			1,0	.040	
	1,6	1/16	42,0001,3583			1,2	.045	42,0100,1003 -red
						1,6	1/16	42,0100,1008 -black

Euro

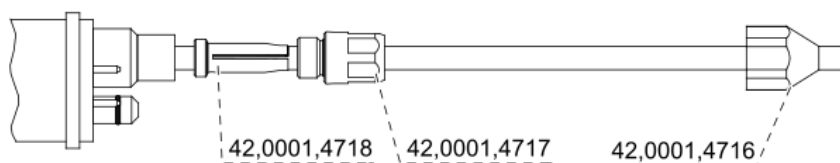

MTW 400d /F++/3.5m/45° (4,035,951,000)

Basic kit 250i / 320i / 400i / 500i / 700i	Ø mm Ø inch		m feet		Fe MTG / MTW Part No.	CrNi MTG / MTW Part No.	Alu MTW Part No.	CuSi MTW Part No.	Alu/CuSi MTG Part No.
		0,8	.030	5,0	11,5	44,0350,5117*	44,0350,5158*	44,0350,5135*	
	0,9	.035	5,0	14,8	44,0350,5118*	44,0350,5159*	44,0350,5136*		44,0350,5145*
	1,0	.040	5,0	11,5	44,0350,5119*	44,0350,5160*	44,0350,5137*		44,0350,5146*
	1,2	.047	5,0	14,8	44,0350,5120*	44,0350,5161*	44,0350,5138*		44,0350,5147*
	1,4	.052	5,0	11,5	44,0350,5121*	44,0350,5162*	44,0350,5139*		44,0350,5148*
	1,6	.062	5,0	14,8	44,0350,5122*	44,0350,5163*	44,0350,5140*		44,0350,5149*

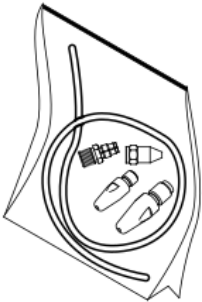
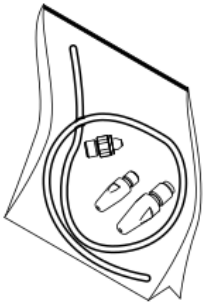
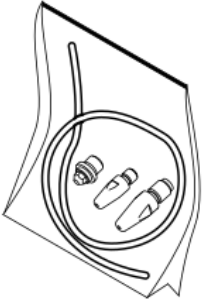
*		
F++ Part No. + ,000 44,0350,xxxx,000	E Part No. + ,001 44,0350,xxxx,001	FSC Part No. 44,0350,xxxx
		

MTW 400d /F++/3.5m/45° (4,035,951,000)

TOOLS

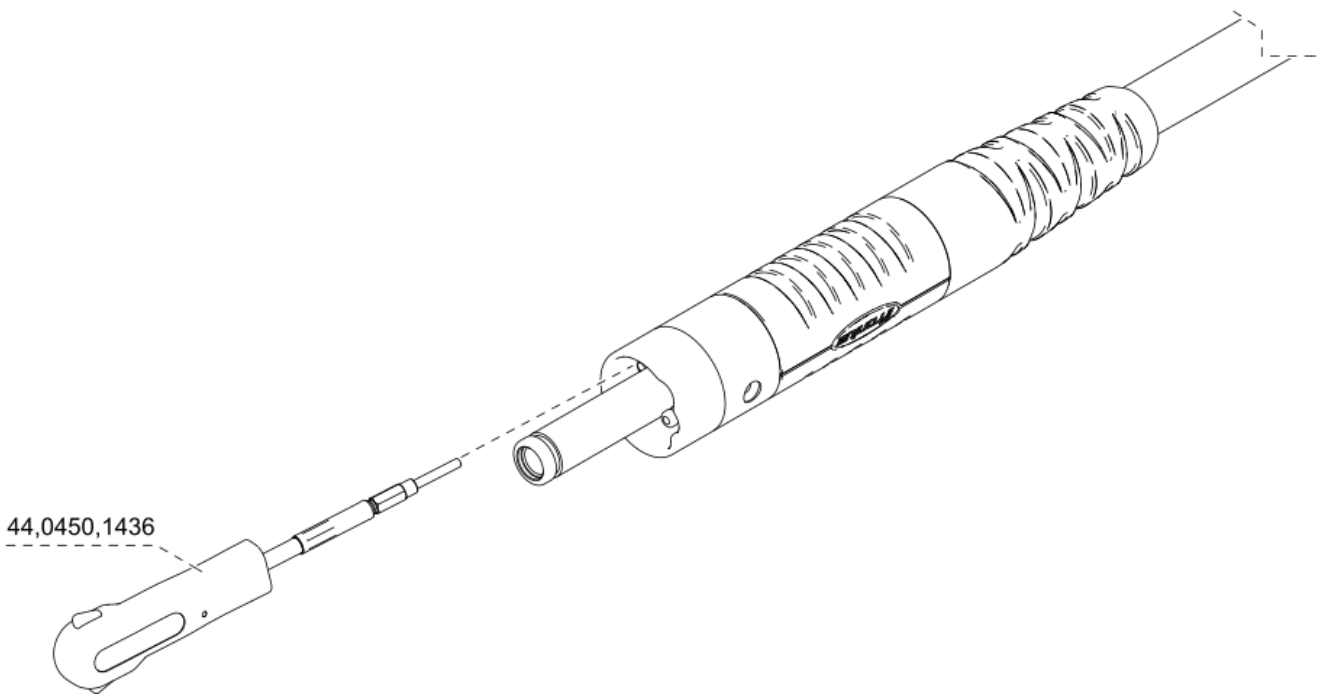
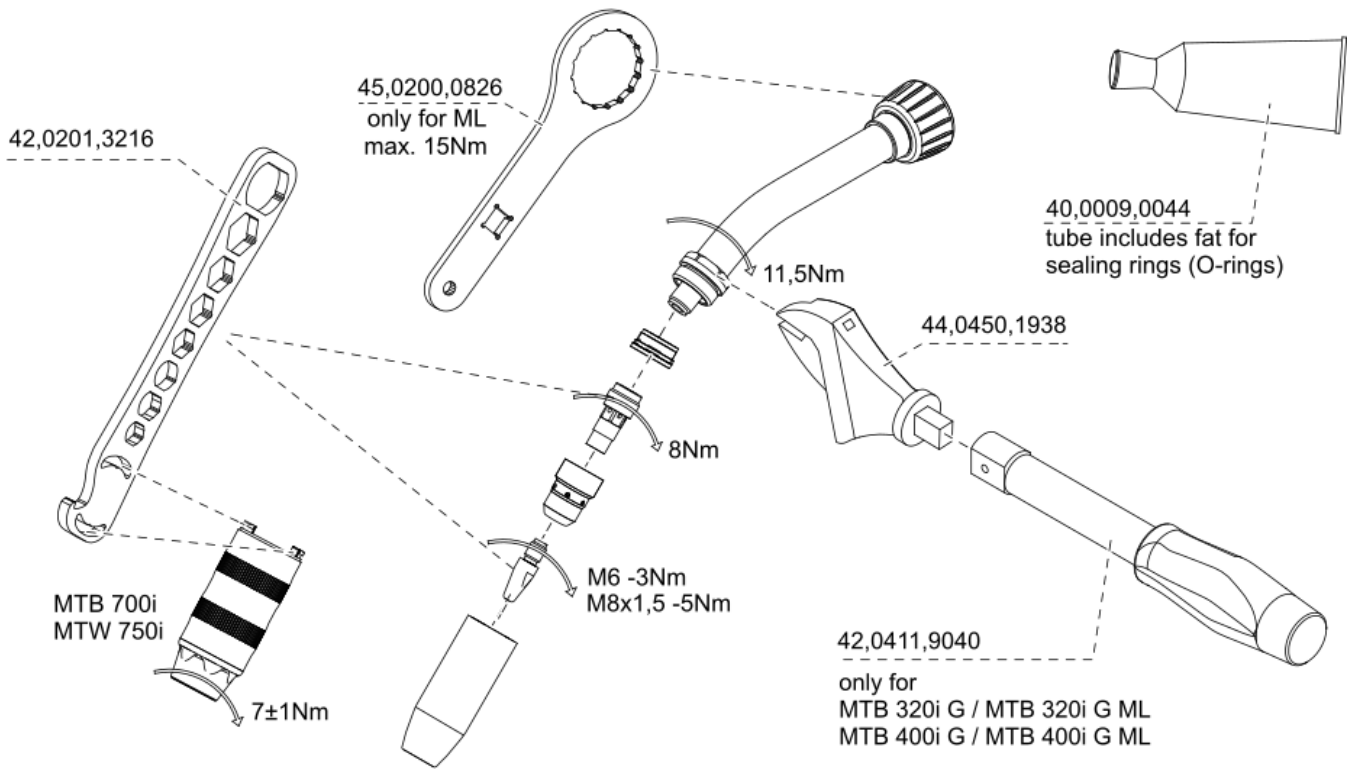

MTW 400d /F++/3.5m/45° (4,035,951,000)

Article no.	Description	Quantity	Unit
42,0407,0245	CLAMP W.INSERT 7,0/ø5,8-7,9	1	pc
42,0402,0286	O-ring ø7.5x1.5mm NBR70	1	pc
42,0407,0284	HOSE CLAMP 1EAR 9,0/ø7,3-9,0	1	pc
44,0350,3440	Wiref. hose 5.7x1.15 3.25m	1	pc
42,0402,0258	O-ring 4x1.2mm FKM	1	pc
42,0407,0100	CABLE FIXING 150	1	pc
42,0405,0561	Union nut M33x2	1	pc
42,0405,0548	Sealing cap for plug nipple	1	pc
42,0405,0753	Heat shield PA6 ø18mm	1	pc
42,0100,1329	Insulating ring W ø20.8/14*7.3	1	pc
42,0001,4037	Nozz.stock M8x1.5/SW13x26.5 CU	1	pc
42,0405,0854	Spatter guard Ø10/Ø20.8x24mm	1	pc
42,0100,1156	Spatter guard ø14,5/ø18x21,3	1	pc
42,0001,6336	Clamping nut Contec/SW11x19,5	1	pc
44,0350,3426	Contec MD nozzle fitt. MTW500i	1	pc
42,0100,1371	Insulation ring Ø20.8/Ø14x8.5	1	pc
42,0100,0591	Spatter guard Ø10/Ø20.8x24mmHD	1	pc
42,0001,4651	Nozzle fit.M8x1.5/SW10x26.5 CU	1	pc
42,0100,1497	Insulation ring ø20.7/ø14x15	1	pc
42,0001,4919	Nozzle fitting M6/SW10x30 CU	1	pc
42,0402,0317	O-ring lø20x1.3 FKM	1	pc
42,0001,4051	Gas nozzle ø15/ø25x63 CT	1	pc
42,0001,4917	Gas noz. narrow Ø13/Ø25x62.5	1	pc
44,0350,3935	Gas nozzle Ø15/Ø25x61 CT/H	1	pc
42,0001,3912 ,100	Contec-Shell 100 pcs MD	1	pk
42,0001,3912 ,10	Contec-Shell 10 pcs MD	1	pk
42,0001,4928	Contact tip 0.6/M6/8x24mm	1	pc
42,0001,6524 ,10	Contact tip 0,7 / M6 / 8x24mm	1	pk
42,0001,4461 ,10	Contact tip 0,8/M6/ø8x24	1	pk
42,0001,4462 ,10	Contact tip 0,9/M6/ø8x24	1	pk
42,0001,4463 ,10	Contact tip 1,0/M6/ø8x24	1	pk

MTW 400d /F++/3.5m/45° (4,035,951,000)

Article no.	Description	Quantity	Unit
42,0001,6527 ,10	Contact tip 1,1 / M6 / 8x24mm	1	pk
42,0001,4464 ,10	Contact tip 1,2/M6/ø8x24	1	pk
42,0001,6529 ,10	Contact tip 1,3 / M6 / 8x24mm	1	pk
42,0001,4465 ,10	Contact tip 1,4/M6/ø8x24	1	pk
42,0001,6522 ,10	Contact tip 1,5 / M6 / 8x24mm	1	pk
42,0001,4466 ,10	Contact tip 1,6/M6/ø8x24	1	pk
42,0001,6482 ,10	Contact tip 0,7/M8x1,5/10x32mm	1	pk
42,0001,6464 ,10	Contact tip 0,8/M8x1,5/ø10x32	1	pk
42,0001,6465 ,10	Contact tip 0,9/M8x1,5/ø10x32	1	pk
42,0001,6466 ,10	Contact tip 1,0/M8x1,5/ø10x32	1	pk
42,0001,6483 ,10	Contact tip 1,1/M8x1,5/10x32mm	1	pk
42,0001,6467 ,10	Contact tip 1,2/M8x1,5/ø10x32	1	pk
42,0001,6484 ,10	Contact tip 1,3/M8x1,5/10x32mm	1	pk
42,0001,6468 ,10	Contact tip 1,4/M8x1,5/ø10x32	1	pk
42,0001,6485 ,10	Contact tip 1,5/M8x1,5/10x32mm	1	pk
42,0001,6469 ,10	Contact tip 1,6/M8x1,5/ø10x32	1	pk
42,0001,6470 ,10	Contact tip 1,8/M8x1,5/ø10x32	1	pk
42,0001,6471 ,10	Contact tip 2,0/M8x1,5/ø10x32	1	pk
42,0001,6472 ,10	Contact tip 2,4/M8x1,5/ø10x32	1	pk
42,0001,4642 ,10	Contact tip 2.8/M8x1.5/ø10x32	1	pk
42,0001,6537 ,10	Cont. tip 0.8/M8x1.5/10x32 Al	1	pk

MTW 400d /F++/3.5m/45° (4,035,951,000)

Article no.	Description	Quantity	Unit
42,0001,4750	Cont. tip 1.0/M8x1.5/ø10x32 Al ,10	1	pk
42,0001,4751	Cont. tip 1.2/M8x1.5/ø10x32 Al ,10	1	pk
42,0001,4752	Cont. tip 1.6/M8x1.5/ø10x32 Al ,10	1	pk
42,0001,6525	Contact tip 0,8 / M6 / 8x24mm ,10	1	pk
42,0001,6526	Contact tip 1,0 / M6 / 8x24mm ,10	1	pk
42,0001,6528	Contact tip 1,2 / M6 / 8x24mm ,10	1	pk
42,0001,6523	Contact tip 1,6 / M6 / 8x24mm ,10	1	pk
42,0001,7025	Contact tip 0.9/M6/ø8x24/SQ ,10	1	pk
42,0001,7026	Contact tip 1.0/M6/ø8x24/SQ ,10	1	pk
42,0001,7027	Contact tip 1.2/M6/ø8x24/SQ ,10	1	pk
42,0001,7028	Cont. tip 0.9/M8x1.5/ø10x32/SQ ,10	1	pk
42,0001,7029	Cont. tip 1.0/M8x1.5/ø10x32/SQ ,10	1	pk
42,0001,7030	Cont. tip 1.2/M8x1.5/ø10x32/SQ ,10	1	pk
42,0402,0304	Sealing ring lø25x1,5 FKM	1	pc
42,0402,0305	Sealing ring lø21x1.5 FKM	1	pc
44,0350,3966	Gas nozzle W 700i ø17/ø29.5x71	1	pc
42,0001,4257	Gas noz. mouthpiece Ø17/Ø29x29	1	pc
44,0350,3942	Gas noz.W 700i ø17/ø29.5x76 HD	1	pc
42,0001,4670	Gas noz. mouthp. ø17/29x34 HD	1	pc
44,0350,4079	Gas noz. W 700i Ø17/Ø29.5x68.5	1	pc
42,0001,4868	Gas noz. mouthpc. Ø17/Ø29x26.5	1	pc
44,0350,1287	Gas nozzle Ø15/Ø25x63 CT/H	1	pc
44,0350,3936	Gas nozzle ø17/ø25x61 CT/H	1	pc
44,0350,0226	Gas nozz. W 700iø13.2/ø29.5x69	1	pc
42,0001,0142	Gas nozzle mouthpiece ø13/ø29x	1	pc
42,0001,6664	Gas nozzle ø8/ø22x57 CT	1	pc
42,0001,4083	Gas nozzle ø10/ø22x54 CT	1	pc

MTW 400d /F++/3.5m/45° (4,035,951,000)

Article no.	Description	Quantity	Unit
42,0001,4799	Gas nozzle ø13/ø22x54 CT	1	pc
42,0001,4477	Gas nozzle ø13/ø22x56 CT	1	pc
42,0001,4084	Gas nozzle ø10/ø22x58 CT	1	pc
42,0001,4498	Gas nozzle ø13/ø22x56 CT/C	1	pc
42,0001,4065	Gas nozzle ø13/ø22x58 CT	1	pc
42,0001,4493	Gas nozzle ø15/ø22x58 CT	1	pc
42,0001,4055	Gas nozzle cyl ø18/ø22x58 CT	1	pc
42,0001,4085	Gas nozzle ø13/ø25x59 CT	1	pc
42,0001,4048	Gas nozzle ø15/ø25x59 CT	1	pc
42,0001,4086	Gas nozzle ø13/ø25x61.5 CT	1	pc
42,0001,4474	Gas nozzle ø15/ø25x61 CT	1	pc
42,0001,4789	Gas nozzle ø15/ø27x61 CT HD	1	pc
42,0001,4476	Gas nozzle ø17/ø25x61 CT	1	pc
42,0001,4497	Gas nozzle ø13/ø25x61 CT/C	1	pc
42,0001,4080	Gas nozzle ø13/ø25x63 CT	1	pc
42,0001,4496	Gas nozzle ø15/ø25x61 CT/C	1	pc
42,0001,4494	Gas nozzle ø17/ø25x61 CT/C	1	pc
42,0001,4050	Gas nozzle ø17/ø25x63 CT	1	pc
42,0001,4216	Gas nozzle ø17/ø27x63 CT HD	1	pc
42,0001,4054	Gas nozzle cyl ø21.1/ø25x63 CT	1	pc
42,0001,4052	Gas nozzle ø15/ø25x68 CT	1	pc
42,0001,4049	Gas nozzle ø17/ø25x68 CT	1	pc
42,0001,4087	Gas nozzle ø13/ø25x71 CT	1	pc
42,0001,4788	Gas nozzle ø15/ø25x71 CT	1	pc
42,0001,4088	Gas nozzle ø13/ø25x73.5 CT	1	pc
42,0001,4475	Gas nozzle ø15/ø25x73 CT	1	pc
42,0001,4790	Gas nozzle ø15/ø27x73 CT HD	1	pc
42,0001,4495	Gas nozzle ø15/ø25x73 CT/C	1	pc
42,0001,4045	Gas nozzle ø15/ø25x75 CT	1	pc
42,0001,4043	Gas nozzle ø17/ø25x75 CT	1	pc
42,0001,4053	Gas nozzle cyl ø21.1/ø25x75 CT	1	pc
42,0001,4047	Gas nozzle ø15/ø25x80 CT	1	pc
42,0001,4533	Gas nozzle ø13/ø24x37 CT	1	pc
42,0001,4487	Gas nozzle ø13/ø25x41 CT	1	pc

MTW 400d /F++/3.5m/45° (4,035,951,000)

Article no.	Description	Quantity	Unit
42,0001,4534	Gas nozzle ø13/ø25x39,5 CT/C	1	pc
42,0001,4902	Gas nozzle ø13/ø25x39.5 CT	1	pc
42,0001,5023	Gas nozzle ø15/ø25x39.5 CT	1	pc
42,0001,4486	Gas nozzle ø13/ø25x41 CT/H	1	pc
42,0001,4745	Gas noz.narrow gap ø13/ø25x56	1	pc
42,0001,6772	Gas noz. nrw gap ø13/ø25x50 CT	1	pc
42,0001,4858	Gas nozzle ø13/ø27x53 CT	1	pc
42,0001,4857	Gas nozzle ø15/ø27x53 CT	1	pc
42,0001,4856	Gas nozzle ø15/ø27x57 CT	1	pc
44,0350,2020	Gas nozzle ø15/ø27x67 CT	1	pc
44,0350,2021	Gas nozzle ø17/ø27x67 CT	1	pc
44,0350,1991	Gas nozzle ø15/ø27x74 CT	1	pc
44,0350,1995	Gas nozzle ø17/ø27x74 CT	1	pc
44,0350,1987	Gas nozzle ø15/ø27x80.5 CT	1	pc
44,0350,1988	Gas nozzle ø15/ø27x82.5 CT	1	pc
44,0350,3179	Gas nozzle ø17/ø27x83.5 CT	1	pc
44,0350,3180	Gas nozzle ø18/ø27x87.5 CT	1	pc
42,0001,6715	Gas nz. nar. gap Ø10/Ø25x68 CT	1	pc
42,0001,6716	Gas nz. nar. gap Ø13/Ø25x68 CT	1	pc
42,0001,4918	Gas noz. narrow Ø13/Ø25x74.5	1	pc
44,0350,2036	Gas nozzle ø17/ø27x85	1	pc
42,0001,0972	Gas nozzle ø15/ø25x69.5	1	pc
40,0001,0529	Graph. liner 0.8(4.7/1.2) 10m ,010	1	pc
40,0001,0530	Graph. liner 1.0(4.7/1.5) 10m ,010	1	pc
40,0001,0531	Graph. liner 1.2(4.7/1.8) 10m ,010	1	pc
40,0001,0532	Graph. liner 1.6(4.7/2.4) 10m ,010	1	pc
40,0001,0529	Graph. liner 0.8(4.7/1.2) 100m ,100	1	pc
40,0001,0531	Graph. liner 1.2(4.7/1.8) 100m ,100	1	pc
40,0001,0530	Graph. liner 1.0(4.7/1.5) 100m ,100	1	pc
40,0001,0533	Graph. liner 2.0(4.7/3.0) 100m ,100	1	pc

MTW 400d /F++/3.5m/45° (4,035,951,000)

Article no.	Description	Quantity	Unit
40,0001,0532 ,100	Graph. liner 1.6(4.7/2.4) 100m	1	pc
40,0001,0533 ,030	Graph. liner 2.0(4.7/3.0) 30m	1	pc
40,0001,0532 ,030	Graph. liner 1.6(4.7/2.4) 30m	1	pc
40,0001,0531 ,030	Graph. liner 1.2(4.7/1.8) 30m	1	pc
40,0001,0530 ,030	Graph. liner 1.0(4.7/1.5) 30m	1	pc
40,0001,0529 ,030	Graph. liner 0.8(4.7/1.2) 30m	1	pc
40,0001,0533 ,010	Graph. liner 2.0(4.7/3.0) 10m	1	pc
44,0350,3410	Combi liner G Al /1.2/4.8m	1	pc
44,0350,3403	Combi liner G Al /1.6/2.0m	1	pc
44,0350,3407	Combi liner G Al /1.6/3.8m	1	pc
44,0350,3411	Combi liner G Al /1.6/4.8m	1	pc
44,0350,3405	Combi liner G Al /1.0/3.8m	1	pc
44,0350,3409	Combi liner G Al /1.0/4.8m	1	pc
44,0350,3402	Combi liner G Al /1.2/2.0m	1	pc
44,0350,3406	Combi liner G Al 1.2/3.8m	1	pc
44,0350,3620	Combi liner G Al /2.0/4.8m	1	pc
44,0350,3619	Combi liner G Al /2.0/3.8m	1	pc
44,0350,3400	Combi liner G Al /0.8/2.0m	1	pc
44,0350,3404	Combi liner G Al /0.8/3.8m	1	pc
44,0350,3408	Combi liner G Al /0.8/4.8m	1	pc
44,0350,3401	Combi liner G Al /1.0/2.0m	1	pc
44,0350,5520	Combination liner G /1.2/4.8m	1	pc
44,0350,5516	Combination liner G /1.6/3.8m	1	pc
44,0350,5521	Combination liner G /1.6/4.8m	1	pc
44,0350,5514	Combination liner G /1.0/3.8m	1	pc
44,0350,5519	Combination liner G /1.0/4.8m	1	pc
44,0350,5515	Combination liner G /1.2/3.8m	1	pc
44,0350,5517	Combination liner G /2.0/3.8m	1	pc
44,0350,5513	Combination liner G /0.8/3.8m	1	pc
44,0350,5518	Combination liner G /0.8/4.8m	1	pc

MTW 400d /F++/3.5m/45° (4,035,951,000)

Article no.	Description	Quantity	Unit
42,0404,0453	Bronze liner 2.7x1.0x40mm	1	pc
42,0404,0192	Bronze inner liner 2,7x1 0,32m	1	pc
42,0100,1370	Connector uni. to liner	1	pc
42,0100,1369	Outlet part to liner MAG02	1	pc
44,0350,3392	Combi liner W Al /0.8/3.8m	1	pc
44,0350,3396	Combi liner W Al /0.8/4.8m	1	pc
44,0350,3393	Combi liner W Al /1.0/3.8m	1	pc
44,0350,3397	Combi liner W Al /1.0/4.8m	1	pc
44,0350,3394	Combi liner W Al /1.2/3.8m	1	pc
44,0350,3398	Combi liner W Al /1.2/4.8m	1	pc
44,0350,3395	Combi liner W Al /1.6/3.8m	1	pc
44,0350,3399	Combi liner W Al /1.6/4.8m	1	pc
44,0350,3616	Combi liner W Al /2.0/3.8m	1	pc
44,0350,3617	Combi liner W Al /2.0/4.8m	1	pc
40,0002,0040	Steel liner exposed 0.8/15m ,015	1	pc
40,0002,0041	Steel liner exposed 1.0 / 15m ,015	1	pc
40,0002,0042	Steel liner exposed 1.2/15m ,015	1	pc
40,0002,0043	Steel liner exposed 1.6/15m ,015	1	pc
40,0002,0044	CrNi liner exposed 0.8/15m ,015	1	pc
40,0002,0045	CrNi liner exposed 1.0/15m ,015	1	pc
40,0002,0046	CrNi liner exposed 1.2/15m ,015	1	pc
40,0002,0047	CrNi liner exposed 1.6/15m ,015	1	pc
40,0002,0052	Steel inner liner C 0.8 / 15 m ,015	1	pc
40,0002,0053	Steel inner liner C 1.0 / 15 m ,015	1	pc
40,0002,0054	Steel inner liner C 1.2 / 15 m ,015	1	pc
40,0002,0055	Steel inner liner C 1.6 / 15 m ,015	1	pc
40,0002,0040	Steel liner exposed 0.8/5m ,005	1	pc

MTW 400d /F++/3.5m/45° (4,035,951,000)

Article no.	Description	Quantity	Unit
40,0002,0041 ,005	Steel liner exposed 1.0/5m	1	pc
40,0002,0042 ,005	Steel liner exposed 1.2/5m	1	pc
40,0002,0043 ,005	Steel liner exposed 1.6/5m	1	pc
40,0002,0044 ,005	CrNi liner exposed 0.8/5m	1	pc
40,0002,0045 ,005	CrNi liner exposed 1.0/5m	1	pc
40,0002,0046 ,005	CrNi liner exposed 1.2/5m	1	pc
40,0002,0047 ,005	CrNi liner exposed 1.6/5m	1	pc
40,0002,0052 ,005	Steel inner liner C 0.8 / 5 m	1	pc
40,0002,0053 ,005	Steel inner liner C 1.0 / 5 m	1	pc
40,0002,0054 ,005	Steel inner liner C 1.2 / 5 m	1	pc
40,0002,0055 ,005	Steel inner liner C 1.6 / 5 m	1	pc
40,0002,0040 ,050	Steel liner exposed 0.8/50m	1	pc
40,0002,0041 ,050	Steel liner exposed 1.0/50m	1	pc
40,0002,0042 ,050	Steel liner exposed 1.2/50m	1	pc
40,0002,0043 ,050	Steel liner exposed 1.6/50m	1	pc
40,0002,0044 ,050	CrNi liner exposed 0.8/50m	1	pc
40,0002,0045 ,050	CrNi liner exposed 1.0/50m	1	pc
40,0002,0046 ,050	CrNi liner exposed 1.2/50m	1	pc
40,0002,0047 ,050	CrNi liner exposed 1.6/50m	1	pc
40,0002,0052 ,050	Steel inner liner C 0.8 / 50 m	1	pc
40,0002,0053 ,050	Steel inner liner C 1.0 / 50 m	1	pc

MTW 400d /F++/3.5m/45° (4,035,951,000)

Article no.	Description	Quantity	Unit
40,0002,0054,050	Steel inner liner C 1.2 / 50 m	1	pc
40,0002,0055,050	Steel inner liner C 1.6 / 50 m	1	pc
44,0350,3388	Combi liner W Al /0.8/2.0m	1	pc
44,0350,3389	Combi liner W Al /1.0/2.0m	1	pc
44,0350,3390	Combi liner W Al /1.2/2.0m	1	pc
44,0350,3391	Combi liner W Al /1.6/2.0m	1	pc
44,0350,5550	Kombiseele G /0,8/2,0m	1	pc
44,0350,5552	Kombiseele G /1,2/2,0m	1	pc
44,0350,5553	Kombiseele G /1,6/2,0m	1	pc
44,0350,5522	Combination liner G /2.0/4.8m	1	pc
44,0350,5554	Kombiseele G /2,0/2,0m	1	pc
44,0350,3615	Combi liner W Al /2.0/2.0m	1	pc
44,0350,3618	Combi liner G Al /2.0/2.0m	1	pc
44,0350,5551	Kombiseele G /1,0/2,0m	1	pc
44,0350,3314	Clamping nipple 0.8 Al / CuSi	1	pc
44,0350,3315	Clamping piece 0.8 Fe / CrNi	1	pc
44,0350,3318	Clamping piece 1.2	1	pc
44,0350,3320	Clamping piece 1.4/1.6	1	pc
44,0350,3317	Clamping piece 0.9 / 1.0	1	pc
44,0350,3321	Clamping piece 2.0 Al	1	pc
42,0001,4589	Clamping piece 2.8 SSFCW	1	pc
44,0350,4245	Clamping piece 2.4 Al	1	pc
42,0001,4717	Clamp. nut Euro plastic liner	1	pc
42,0001,4716	Inlet noz. for graph. liner ø5	1	pc
42,0001,4718	Collet Euro plastic liner ø4.7	1	pc
44,0350,3703	Clamping piece 0.8/E	1	pc
44,0350,3704	Clamping piece 1.0/E	1	pc
44,0350,3706	Clamping piece 1.6/E	1	pc
44,0350,3705	Clamping piece 1.2/E	1	pc
42,0100,1003	Guide nozzle 1,2	1	pc
42,0100,1120	Guide nozzle ø0,8 gray	1	pc
42,0100,1008	Guide nozzle 1,6	1	pc
42,0100,1119	Guide nozzle ø1,0 Drive	1	pc

MTW 400d /F++/3.5m/45° (4,035,951,000)

Article no.	Description	Quantity	Unit
42,0400,1024	Clamping nut for nozzle	1	pc
42,0001,3583	clamping piece ZYL. Aø4,7-4,9	1	pc
42,0001,5833	Clamping piece zyl. Aø4,1-4,3	1	pc
42,0001,4512	clamping piece ZYL. AØ4,6-Ø4,8	1	pc
44,0350,3769	Inlet noz. gas pl./0.8 compl.	1	pc
44,0350,3770	Inlet noz. gas pl./1.0 compl.	1	pc
44,0350,3772	Inlet noz. gas pl./1.6 compl.	1	pc
44,0350,3771	Inlet noz. gas pl./1.2 compl.	1	pc
44,0350,5122	BK Fe ø1.6 /G/W/5m	1	pc
44,0350,5121	BK Fe ø1.4 /G/W/5m	1	pc
44,0350,5120	BK Fe ø1,2 G/W/5m MTG/MTW Fe	1	pc
44,0350,5119	BK Fe ø1,0 G/W/5m MTG/MTW Fe	1	pc
44,0350,5118	BK Fe ø0.9 /G/W/5m	1	pc
44,0350,5117	BK Fe ø0.8 /G/W/5m	1	pc
44,0350,5163	BK CrNi ø1.6 /G/W/5m	1	pc
44,0350,5162	BK CrNi ø1.4 /G/W/5m	1	pc
44,0350,5161	BK CrNi ø1,2 G/W/5m MTG/MTW	1	pc
44,0350,5160	BK CrNi ø1,0 G/W/5m MTG/MTW	1	pc
44,0350,5159	BK CrNi ø0.9 /G/W/5m	1	pc
44,0350,5158	BK CrNi ø0.8 /G/W/5m	1	pc
44,0350,5139	BK Al ø1.4 /W/5m	1	pc
44,0350,5136	BK Al ø0.9 /W/5m	1	pc
44,0350,5140	BK Al ø1.6 /W/5m	1	pc
44,0350,5138	BK Al ø1,2 W/5m MTW	1	pc
44,0350,5137	BK Al ø1.0 /W/5m	1	pc
44,0350,5135	BK Al ø0.8 /W/5m	1	pc
44,0350,5148	BK Al ø1.4 /G CuSi ø1.4 G/W/5m	1	pc
44,0350,5145	BK Al ø0.9 /G CuSi ø0.9 G/W/5m	1	pc
44,0350,5149	BK Al ø1.6/G CuSi ø1.6 G/W/5m	1	pc
44,0350,5147	BK Al ø1.2 /G CuSi ø1.2 G/W/5m	1	pc
44,0350,5146	BK Al ø1.0 /G CuSi ø1.0 G/W/5m	1	pc
44,0350,5144	BK Al ø0.8 /G CuSi ø0.8 G/W/5m	1	pc
44,0450,1436	Extract. tool CPC+35mm extens.	1	pc
42,0201,3216	Multitool TB wear parts	1	pc

MTW 400d /F++/3.5m/45° (4,035,951,000)

Article no.	Description	Quantity	Unit
40,0009,0044	GREASE O-ring	1	pc
45,0200,0826	Torque wrench union nut BY	1	pc
44,0450,1938	Adjustable spanner	1	pc
42,0411,9040	Torque wrench 4-20Nm	1	pc